

**IST8309**

**3D Magnetometer with**

**Programmable Switch**

**Preliminary Datasheet**

**Table of Contents**

- 1. GENERAL DESCRIPTION.....3**
- 2. BLOCK DIAGRAM, PACKAGE DIMENSIONS, MAGNETIC FIELD DIRECTION.....4**
  - 2.1. Block diagram.....4
  - 2.2. Package Dimensions.....4
  - 2.3. Marking.....5
  - 2.4. Magnetic Field Direction.....5
- 3. OPERATIONAL MODES AND FUNCTIONAL DESCRIPTIONS .....6**
  - 3.1. Operation Modes .....6
- 4. ELECTRICAL SPECIFICATIONS .....6**
  - 4.1. Absolute Maximum Ratings .....6
  - 4.2. Recommended Operating Conditions .....7
  - 4.3. Electrical Specifications .....7
  - 4.4. Magnetic Sensor Specifications.....8
  - 4.5. Power-On Reset (POR) Specifications .....8
- 5. ORDERING INFORMATION.....9**
- 6. LEGAL DISCLAIMER .....9**
  - 6.1. Warranty and Liability Disclaimer.....9
  - 6.2. Applications Disclaimer.....9
  - 6.3. Disclaimer Regarding Changes .....9

## 1. General Description

iSentek IST8309 is a 3D digital linear hall sensor to measure magnetic flux intensity. It is an IC device that contains magnetic sensors and control ASIC with a 16-bit ADC output. IST8309 provides an I<sup>2</sup>C digital output with a fast mode up to 400 kHz. Wide dynamic range operation, high resolution, and compact form factor features make it the best candidate for smartphone, wearable, and IoT devices.

### Features

- Single-chip 3-axis linear hall sensor with digital output
- 3-axis programmable magnetic switch function
- INTB pin for event notification (magnetic switch, DRDY, overflow)
- Compact form factor, 1.29 x 0.99 x 0.53 mm<sup>3</sup>, 5-pin WLCSP-BGA package
- I<sup>2</sup>C bus supports fast mode up to 400 kHz
- Two slave address
- The high dynamic range of a maximum of  $\pm 30$  mT
- High resolution of maximum of 2.5 uT/LSB
- Absolute 360° angle output
- The high output data rate of maximum of 500 Hz
- Operation temperature -30~85 °C
- Built-in oscillator for internal clock source
- Power-on reset circuit

### Applications

Magnetometer for external magnetic detection

Displacement detection

Foldable device angle detection

Angle sensor application

## 2. Block Diagram, Package Dimensions, Magnetic Field Direction

### 2.1. Block diagram

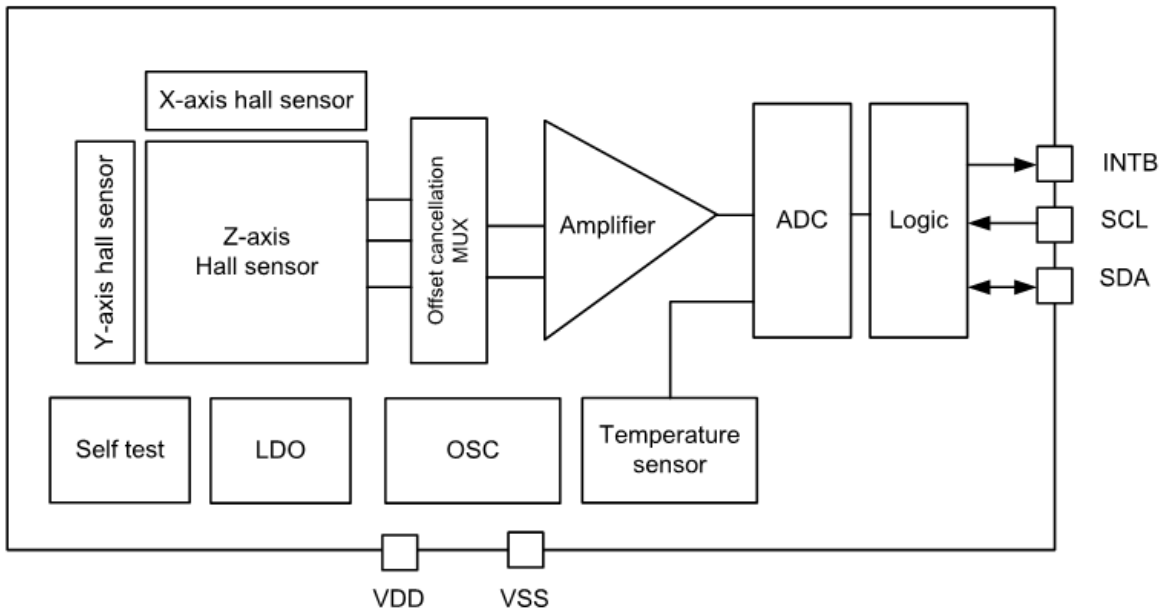

Figure 1. Block Diagram

### 2.2. Package Dimensions

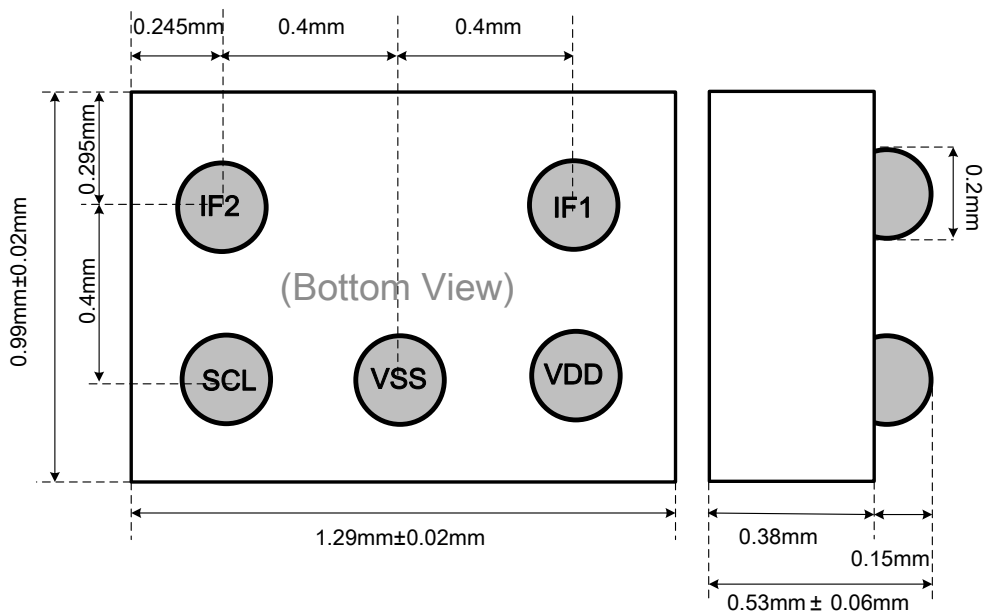

Figure 2. Package Dimensions

## 2.3. Marking

Date code  $X_1X_2X_3\bullet$

Product code  $X_4X_5X_6X_7$

$X_1$ : Year

$X_2X_3$ : Week

$X_4X_5X_6X_7$ : Product code

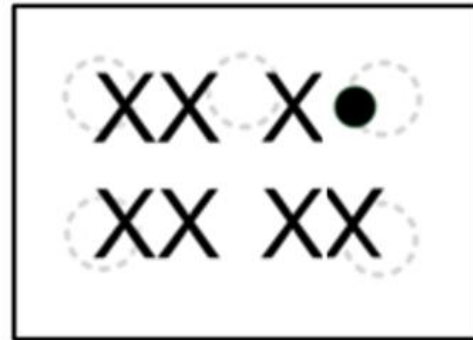

IST8309 TOP View

## 2.4. Magnetic Field Direction

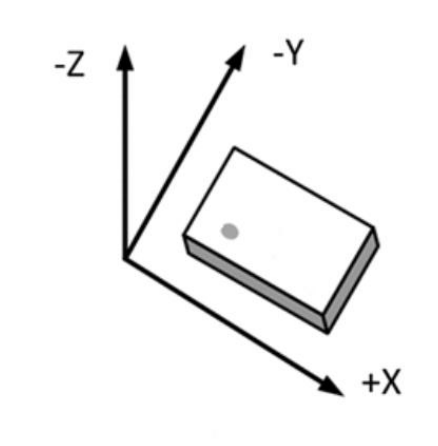

Figure 3. Magnetic Field Direction

### 3. Operational Modes and Functional Descriptions

#### 3.1. Operation Modes

IST8309 has the following operation modes:

- (1) Standby mode
- (2) Single measurement mode
- (3) Continuous measurement mode
- (4) Self-test mode

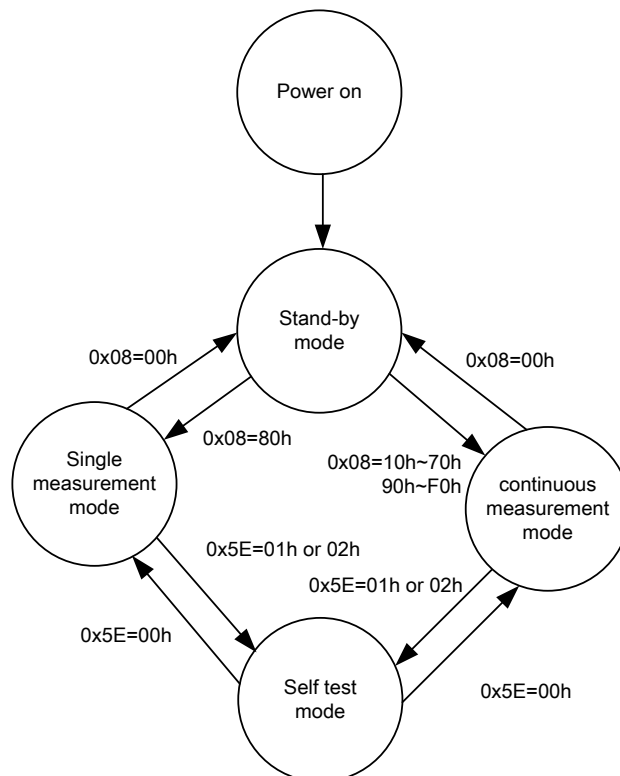

Figure 7. Operation Modes

### 4. Electrical Specifications

#### 4.1. Absolute Maximum Ratings

Parameter	Symbol	Limits	Unit
Storage Temperature	TCG	-40 to +125	°C
Power Supply Voltage (VDD)	VDD	-0.3 to +4.0	V
Electrostatic Discharge Voltage* <sup>1</sup>	VESD_HBM	-2000 to 2000	V
Electrostatic Discharge Voltage* <sup>2</sup>	VESD_CDM	-1000 to 1000	V
Reflow Classification	JESD22-A113 with 260°C Peak Temperature		

If the device is used in conditions exceeding these limits, it may malfunction permanently. Performance cannot be assured when these limits are exceeded.

1. Human Body Model (HBM)
2. Charge Device Model (CDM)

## 4.2. Recommended Operating Conditions

Parameter	Symbol	Min.	Typ.	Max.	Unit
Operating Temperature	TA	-30		+85	°C
Power Supply Voltage (VDD)	VDD	1.7	3.3	3.6	V

## 4.3. Electrical Specifications

Operating conditions: TA = +25 °C; VDD = 3.3 V.

Parameter	Symbol	Pin	Conditions	Min.	Typ.	Max.	Unit
Current Consumption	IDD	VDD	10 Hz sampling		50		uA
Standby Consumption	CUP	VDD	Suspend mode		1		uA
Input current	IAN	SCL, IF1, IF2	GND or VDD	-10		10	uA
Input Low Voltage	VIL	SCL, IF1, IF2		-0.3		0.42	V
Input High Voltage	VIA	SCL, IF1, IF2		0.89		VDD	V
Output Low Voltage	VOL	IF1, IF2				0.3	V
Hysteresis Input	VHS	SCL, IF1, IF2		0.2			V

## 4.4. Magnetic Sensor Specifications

Operating conditions: TA = +25 °C; VDD = 3.3 V.

Parameter	Symbol	Condition	Min.	Typ.	Max.	Unit
Dynamic Range	DR			±30		mT
Resolution	RES	16-bit setting		2.5		μT/LSB

## 4.5. Power-On Reset (POR) Specifications

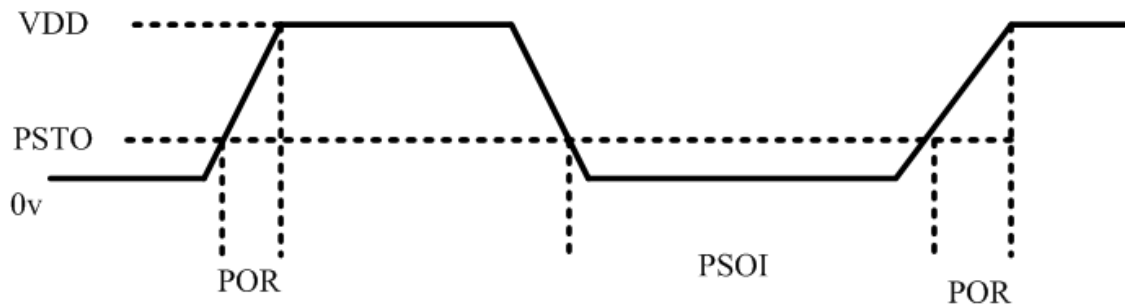

PSTO: Power Supply Turn Off voltage  
 PSOI: Power Supply Turn Off Interval  
 POR: Power On Reset

PSTO: max=0.1 volt  
 PSOI: min=30ms  
 POR: max:50ms

When the POR circuit detects an increase in VDD value, it resets all internal circuits and initializes all registers. After being reset, IST8309 transits to Standby Mode.



## 5. Ordering Information

Order Number	Package Type	Packaging	Temperature Range	Marking Information
IST8309	WLCSP – 5 pins	Tape and Reel: 5k pieces per reel	-30 to +85°C	X <sub>1</sub> X <sub>2</sub> X <sub>3</sub> ● X <sub>4</sub> X <sub>5</sub> X <sub>6</sub> X <sub>7</sub> X <sub>1</sub> : Year X <sub>2</sub> X <sub>3</sub> : Week X <sub>4</sub> X <sub>5</sub> X <sub>6</sub> X <sub>7</sub> : Product code

For further information about iSentek's Magnetic Sensors, please contact +86-156-22888- 337 (China) or +886-2-2698-3306 ext: 111 (Taiwan); send an email to [sales@isentek.com](mailto:sales@isentek.com) visit our website at [www.isentek.com](http://www.isentek.com).

## 6. Legal disclaimer

### 6.1. Warranty and Liability Disclaimer

iSentek Inc. warrants the information in this datasheet. It is assumed that the specification is accurate and reliable. However, iSentek Inc. makes no warranties or claims regarding the accuracy or completeness of this information and takes no responsibility for the use of the information, nor does it convey any license under its patent rights or the rights of third parties.

iSentek Inc. shall not be liable for any consequential, incidental, indirect, or punitive damages (including but not limited e.g. profits loss, business interrupt, further expenses related to removal, replacement or rework of any products).

### 6.2. Applications Disclaimer

iSentek's products are unsuitable for life-critical and safety-critical applications. No liability is claimed by iSentek for the use of its products in such applications. The customer agrees to indemnify and hold iSentek harmless from and against any and all liabilities and losses.

### 6.3. Disclaimer Regarding Changes

iSentek reserves the right to modify the contents of this datasheet, including specifications and descriptions, at any time and without prior notice. This document supersedes all previously issued information.